

Specify pole height. For poles and accessories, see chapter: Poles

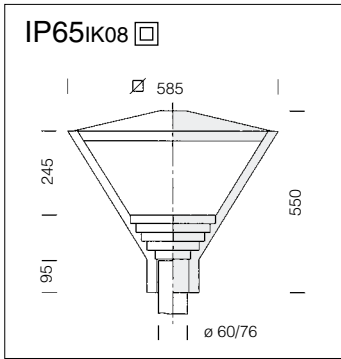

**Housing/Cover:** Made of die-cast aluminium.

**Diffuser:** vandal-resistant, V2 self-extinguishing, UV stabilised, smooth, clear and opal polycarbonate.

**Coating:** In several stages. Epoxy cationic electrocoating, resistant to corrosive and saline environments (UNI ISO 9227), followed by UV stabilising priming, and final stage: a rough finish of grey or sanded silver acrylic coating.

**Equipment:** Removable gear tray and lampholder. Knife switch included in standard supply. Fibreglass nylon cable gland, Ø 1/2 gas (cable min. Ø9 max Ø12). Environment-friendly gasket.

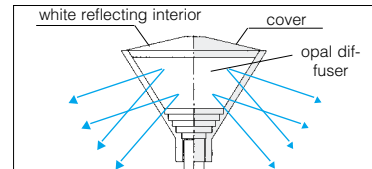
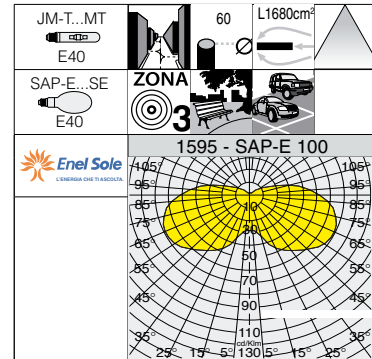

1595 Vista - with opal diffuser				
		CNRL		Lamps (Ta=25°C)
wattage	colour	weight	code	Kelvin - ølm - Ra
JM-T 150	graphite	13.10	422271-00	4000K - 14000 lm - Ra 1b
JM-T 150	s. silver	13.10	422266-00	
SAP-E 100	graphite	13.10	422261-00	2000K - 8500lm - Ra 4
SAP-E 100	s. silver	13.10	422268-00	
JM-T 250	graphite	14.10	422262-00	5200K - 20000lm - Ra 1b
JM-T 250	s. silver	14.10	422270-00	

**On request:** possibility of versions with COSMOPOLIS WHITE Lamps 60W/6850lm/2800K.

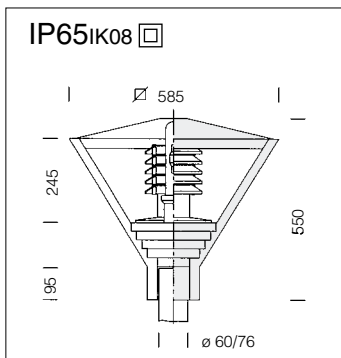
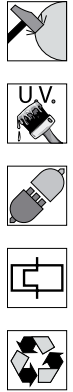

**Reflector:** fitted with white anti-glare directional louvre.

**Diffuser:** in vandal resistant, V2 self-extinguishing polycarbonate, UV stabilized, smooth and clear.

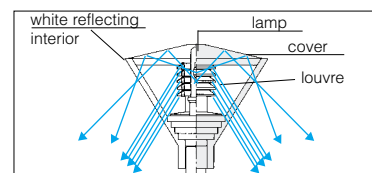
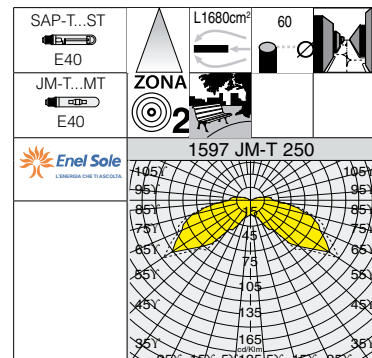

1597 Vista - with louvre				
		CNRL		Lamps (Ta=25°C)
wattage	colour	weight	code	Kelvin - ølm - lm/W - Ra
SAP-T 150	graphite	14.20	422245-00	2000K - 17200lm - Ra 4
SAP-T 150	s. silver	14.20	422243-00	
JM-T 250	graphite	15.00	422246-00	5200K - 20000lm - Ra 1b
JM-T 250	s. silver	15.00	422248-00	



L1680cm<sup>2</sup>

SAP-TS...SD  
Rx7s

JM-TS...MD  
Rx7s

**ZONA 2**

1598 - JM-TS 250

Enel Sole  
L'ENERGIA CHE TI ASSICURA

reflecting optics al. 99.85

lamp

reflector

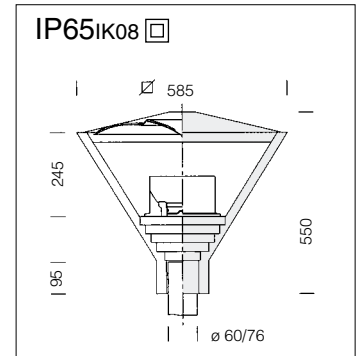

**Reflector:** fitted with aluminium optic unit.

**Diffuser:** in vandal resistant, V2 self-extinguishing polycarbonate, UV stabilized, smooth and clear.

**1598 Vista - indirect light**

wattage	colour	CNRL		Lamps (Ta=25°C)
		weight	code	Kelvin - ølm - Ra
SAP-TS 150	graphite	12.50	422255-00	2000K - 15000lm - Ra 4
SAP-TS 150	s. silver	12.50	422253-00	
JM-TS 150	graphite	12.50	422256-00	4200K - 12000lm - Ra 1b
JM-TS 150	s. silver	12.50	422254-00	
JM-TS 250	graphite	13.30	422257-00	5400K - 20000lm - Ra 1b
JM-TS 250	s. silver	13.30	422258-00	

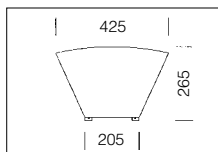

**acc. 110 anti-glare shield**

white 991327-00

Microperforated sheet metal To prevent glare effects. To be fitted inside art. 1598 when the latter is installed near a window..

L1680cm<sup>2</sup>

JM-T...MT  
E40

SAP-T...ST  
E40

**ZONA 2**

1599 - JM-T 250

Enel Sole  
L'ENERGIA CHE TI ASSICURA

reflecting optics al. 99.85

lamp

reflector

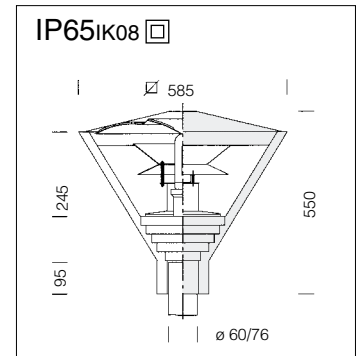

**Reflector:** fitted with aluminium optic unit.

**Diffuser:** in vandal resistant, V2 self-extinguishing polycarbonate, UV stabilized, smooth and clear.

**1599 Vista - with aluminium reflector**

wattage	colour	CNRL		Lamps (Ta=25°C)
		weight	code	Kelvin - ølm - Ra
JM-T 250	graphite	16.00	422296-00	5200K - 20000lm - Ra 1b
JM-T 250	s. silver	16.00	422293-00	
SAP-T 150	graphite	15.00	422297-00	2000K - 17200lm - Ra 4
SAP-T 150	s. silver	15.00	422294-00	
CDO-TT 150	graphite	15.00	422298-00	2800K - 13500lm - Ra 1a
CDO-TT 150	s. silver	15.00	422295-00	

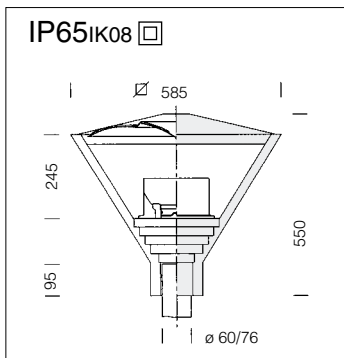

**Optic unit:** LIGHT POLLUTION PREVENTING aluminium optic unit with black lamp holder.

**Diffuser:** in vandal resistant, V2 self-extinguishing polycarbonate, UV stabilized, smooth and clear.

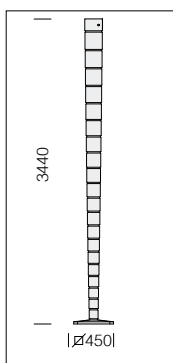
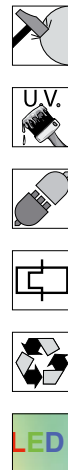
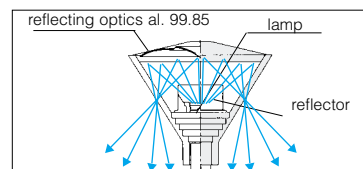
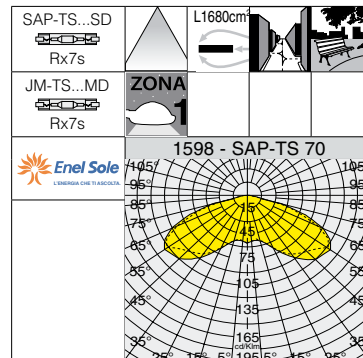

1598 Vista - for zone 1					
		CNRL		Lamps (Ta=25°C)	
wattage	colour	weight	code	Kelvin - ølm - Ra	
SAP-TS 70	graphite	11.80	422310-00	2000K - 6800lm - Ra 4	
JM-TS 70	graphite	11.80	422311-00	3000K - 5100lm - Ra 2a	
SAP-TS 150	graphite	12.50	422312-00	2000K - 15000lm - Ra 4	
JM-TS 150	graphite	12.50	422314-00	4200K - 12000lm - Ra 2a	

acc. 1510 Ambrosiano pole	
s. silver	426360-00
graphite	426359-00

In cast iron. Complete with base.  
Internal tube Ø 70mm.

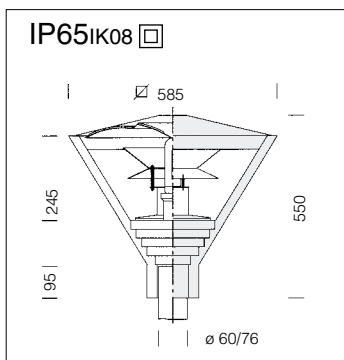

**Optic unit:** LIGHT POLLUTION PREVENTING luminous black aluminium optics.

**Diffuser:** in vandal resistant, V2 self-extinguishing polycarbonate, UV stabilized, smooth and clear.

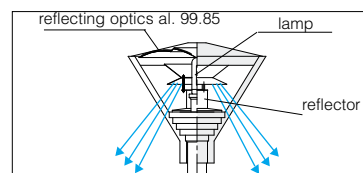
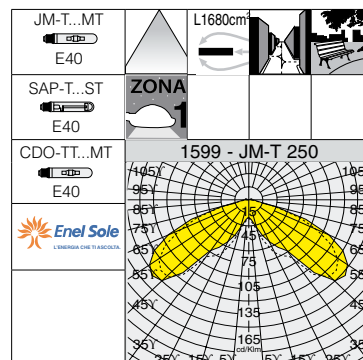

1599 Vista - light pollution preventing optical system					
		CNRL		Lamps (Ta=25°C)	
wattage	colour	weight	code	Kelvin - ølm - Ra	
JM-T 250*	graphite	16.00	422296-0016	5200K - 20000lm - Ra 1b	
JM-T 250*	s. silver	16.00	422293-0016		
SAP-T 150	graphite	15.00	422297-0016	2000K - 17200lm - Ra 4	
SAP-T 150	s. silver	15.00	422294-0016		
CDO-TT 150	graphite	15.00	422298-0016	2800K - 13500lm - Ra 1a	
CDO-TT 150	s. silver	15.00	422295-0016		

\* only for zone 1 (UNI 10819)